



Junior Division

Week: February 7-11

Monday's Activities

Theme: Action and Adventure

Story of the Week

[Media Meltdown: A Graphic Guide Adventure](#)

When Karl Reed, Owner of Oasis Developments, tries to force the sale of a local fruit farm—through whatever means necessary—Pema, Bounce and Jagroop decide to expose him through the media. Little do they realize that when it comes to the news and the advertisers who make it possible, the truth is not always part of the story and nothing can be taken at face value. While learning about media consolidation and the power of money over truth, Bounce, Pema and Jagroop decide to take on the developers and the media.

Let's Explore Literacy

You may have seen on the news over that last week or so that there was a protest held in Ottawa by truckers from across the nation. Read the article, "[Canadian Truckers Protest Vaccine Rules](#)" and answer the following questions:

Have you ever believed in something so strongly that you wanted to hold or join a demonstration to make your views known? What was it? If not, what is an example of something that you might want to protest for or against? How would you protest?

Do you agree with the truckers' protest? Use evidence from the article to support your opinion.

Let's Explore Math

The Rubik's Cube is a 3-D combination puzzle **invented in 1974 by Hungarian sculptor and professor of architecture Ernő Rubik**. Originally called the Magic Cube, the puzzle was licensed by Rubik to be sold by Ideal Toy Corp. in 1980.

Below is a picture of a Rubik's Cube and one possible net for a Rubik's Cube. Can you find all the other possible nets? (Hint: There are 11 in total)

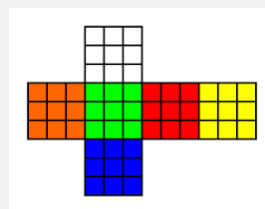
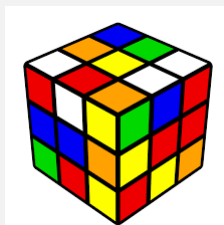



Junior Division

Week: February 7-11

Monday's Activities

Theme: Action and Adventure

Let's Explore Art & Movement

Silly Drawing Prompts. Grab a pencil, a piece of paper and your laughter as you work away at some of these [drawing prompts](#).



When you've tried a few of these, consider creating a silly prompt list of your own. Be prepared to share a silly drawing prompt of your own with us tomorrow in the chat.

Experiential Learning Activity

Asynchronous Event that was previous recorded.

Exploring By the Seat of Your Pants

Belugas and the Whales of the St. Lawrence River: Join in a pre-recorded session.

Follow [this link](#) to see the session. Many questions and answers coming from classrooms around the world.



Junior Division Week: February 7-11 Tuesday's Activities

Theme: Action and Adventure

Story of the Week

[Media Meltdown: A Graphic Guide Adventure](#)



Let's Explore Literacy

Israeli scientists teach goldfish to operate vehicle. No this isn't a silly drawing prompt from yesterday's work. Click on the [link](#) to discover the curious real life tale of a goldfish who drives!

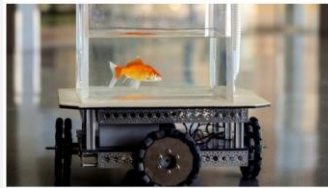

Have you ever trained a pet to do a task (shake a paw, fetch, etc)?
How did you do it?
What other tricks have you seen animals do?

Let's Explore Math

Sammi is applying for a job. In the table below shows the hourly wages of the employees at each company.

- 1) Find the mean, median and mode for the hourly rate at each company.
- 2) Which company should Sammi work for? Justify your choice.

Hourly Rate	
Company A	15, 17, 18, 15, 15, 15, 13, 13
Company B	28, 13, 14, 15, 13, 13, 15, 15



Junior Division
 Week: February 7-11
 Tuesday's Activities

Theme: Action and Adventure

**Let's Explore
 Art
 & Movement**

One way to combat screen time is through physical activity. Let's get up and move. Complete the following exercise regimen: Let's play "Would You Rather?" Each choice you make leads to a different exercise. Here we go...



Click [here](#) to begin

**Experiential
 Learning
 Activity**

Remember last week when Sandy from HCA talked about tracks in the snow? Can you find what happens to these animals and how they live in the winter?

Use [this chart](#) to help you as you research how different animals behave during the winter months.

What do animals do in the winter that is like humans?

Why is it important to protect the land that animals live in?

How might we be able to balance both human needs and animal needs?

What can you do to help?



Junior Division Week: February 7-11 Wednesday's Activities

Theme: Action and Adventure

Story of the Week

[Media Meltdown: A Graphic Guide Adventure](#)



Let's Explore Literacy

Read the following article about the famous abstract painter, Piet Mondrian.
[WHO IS PIET MONDRIAN?](#)

What are your thoughts on abstract art? Imagine you are creating an email to Piet Mondrian explaining your thoughts on abstract art. What would you say? What questions would you like to ask him?

Let's Explore Math

Look at the image below and answer the questions that follow:

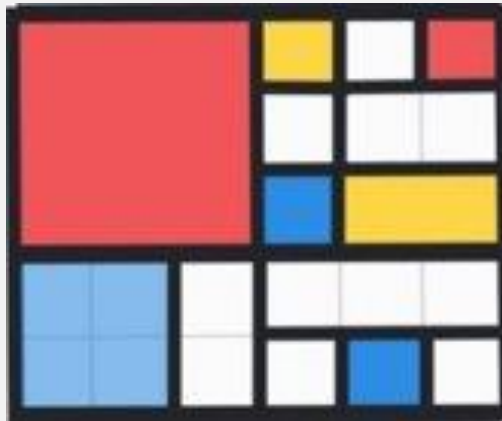

What fraction of the square is red?
What fraction of the square is yellow?
What fraction of the square is white?
What strategies did you use to arrive at your answers?



Junior Division
Week: February 7-11
Wednesday's Activities

Theme: Action and Adventure

**Let's Explore
 Art
 & Movement**

Piet Mondrian was a famous painter who was a revolutionary artist in the field of modern art. The previous fraction activity was actually one of his pieces of art. Let's learn a little bit more about Mondrian and create a piece of artwork inspired by his work.

Watch this lesson and then create your own Mondrian artwork.



Click [here](#) to view the lesson

**Experiential
 Learning
 Activity**

Live Event!

Hamilton Conservation Authority

1:00-1:30 Habitats – How do animals live and grow? Come and find out!

[Please connect to the session here!](#)



Junior Division Week: February 7-11 Thursday's Activities

Theme: Action and Adventure

Story of the Week

[Media Meltdown: A Graphic Guide Adventure](#)



Let's Explore Literacy

Read the article, "[Sniffer Dogs Could Help Prevent the Spread of Covid 19](#)", and choose 3 out the following questions to answer:

- Dogs smelling a virus— even when the person has no symptoms? It sounds like fake news, but it's not. It's true. What research would you do to confirm that this story is real and not fake? What else tells you it's real?
- Why is it important that COVID-19 is identified as early as possible?
- Once a sniffer dog identifies someone with COVID-19, what do you think would happen next?
- Most dogs have more scent receptors in their nose than humans. This allows them to smell things we can't. Think about the other senses: taste, touch, sight and hearing. How do humans compare to dogs or other animals?
- Why are Labrador retrievers, golden retrievers and cocker spaniels best suited to becoming sniffer dogs?

Let's Explore Math

The design on the right-hand side is of a go kart created by a student named Jamil. Jamil wants to decorate the edge of the go kart with fancy tape.

- Regular glow-in-the-dark tape costs \$6.00 per metre
- Sparkly purple tape costs \$7.50 per metre.

Design a colour scheme for Jamil's go-kart tape. How much will the tape for your design cost? Explain your calculations.

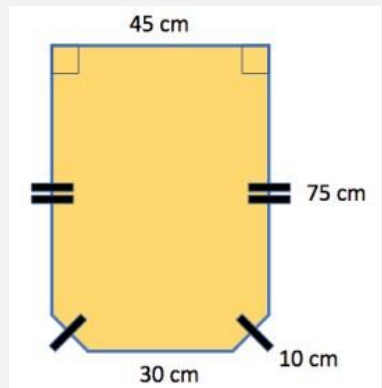



Junior Division

Week: February 7-11

Thursday's Activities

Theme: Action and Adventure

Let's Explore Art & Movement

Nothing is better for your mental health than getting exercise outside in the fresh air. Unplug and go for a walk around your neighbourhood. Try to keep your pace nice and brisk to get your heart rate up. Start out with 30 minutes and see if you can increase the time each day.



If going outside is not an option, try putting on your favourite songs and dancing in the living room for 30 minutes.

Experiential Learning Activity

Live Event

Adventureworks – Goal Setting

10:00 – 11:00 Junior and Intermediate

How are you with goal setting? Join us for FUN activities connecting our communication and goal setting!

[Please connect to the session here!](#)



Junior Division Week: February 7-11 Friday's Activities

Theme: Action and Adventure

Story of the Week

[Media Meltdown: A Graphic Guide Adventure](#)



Let's Explore Literacy

Homonyms are words that are spelled the same but have different meanings in different contexts. For instance, the word mean is a homonym.

- Alex was mean to me.
- I mean you should pick up 5 straws.

Write a story that uses at least 2 homonyms from the following list. Each homonym must be used twice. Each use of the homonym should capture a different meaning of the word.

- times, depression, horns, live, strike, shows, cheap, bat, fly, ring, tie, can, rose, nail, sink

Let's Explore Math

According to the pictograph,

- Which restaurant sold \$400 in hamburgers?
- Which restaurant sold twice as many as A&W?
- What fraction of all the sales was Wendy's?
- How much \$ in sales did all four restaurants sell combined?





Junior Division
 Week: February 7-11
 Friday's Activities

Theme: Action and Adventure

**Let's Explore
 Art
 & Movement**

Today we will be participating in some exercises intended to help athlete's warm-up before physical activity. These exercises help athletes prevent injuries. After you are finished with the stretches it's time to exercise. Go for a walk, a jog or fire up the dance music if you can't go outside.

Click [here](#) for the warm-up.

**Experiential
 Learning
 Activity**

Reflection for the week! On a piece of paper write down:

Plate: Make a list of what is on your plate right now.

Fork: What was new for you this week? What did you have to dig into?

Napkin: What did you help do this week? What might you need to clean up?

Knife: What can you do to share what you have? What do you have to cut away?

Spoon: What did you need help with this week?

Cup: What do you need to do more of after this week? What can you put in your cup to help you move forward?

Placemat: Who supported you this week? What gave you strength?

