

Dundas Valley Secondary School

Grade 8 Option Presentation



“An empathetic culture of respect and learning through the lens of Human Rights”





Academics

How do you graduate?



**CLASS OF
2022**

Ontario Secondary School Diploma (OSSD)



Credit Requirements

30 credits to graduate... 18 **compulsory** courses
+12 **optional** courses

Grades 9, 10, and 11 - **8 credits** earned each year
($3 \times 8 = 24$)

Grade 12 - **6 credits earned** and possibly 2 study periods
(total = 30)

Courses are divided between **2 semesters** - 4 credits per semester

Final **exams** are compulsory and written in January and June.

What else do you need to graduate?

40 hours of community involvement activities

(see hwdsb.on.ca for detailed information and forms)

*Students enter hours in **The Hub** using **Hour Republic** after mid-August*

Pass the provincial literacy requirement

(written in grade 10)

Examples of non-profit organizations:

- ✿ Routes Youth Centre
- ✿ Youth athletic organizations
- ✿ Retirement homes
- ✿ Religious organizations
- ✿ Service clubs
- ✿ Schools
- ✿ Camps

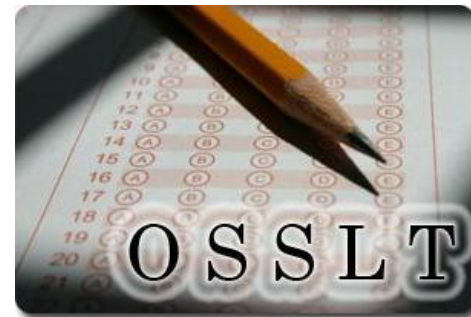

MORE Options Each Year

Grade 9	Grade 10	Grade 11	Grade 12
<i>English</i>	<i>English</i>	<i>English</i>	<i>English</i>
<i>Math</i>	<i>Math</i>	<i>Math</i>	<i>5+ Optional Credits</i>
<i>Science</i>	<i>Science</i>	<i>6 Optional Credits</i>	
<i>Geography</i>	<i>History</i>		
<i>French</i>	<i>Civics/Careers</i>		
<i>Phys. Ed.</i>	<i>3 Optional Credits</i>		
<i>2 Optional Credits</i>			

Types of Courses

Academic	Applied	Locally Developed	Open	Enriched
<i>emphasize theory and abstract thinking</i>	<i>focus on practical applications</i>	<i>prepare for the workplace and applied courses</i>	<i>combine all types of thinking</i>	<i>Enriched Academic courses</i>
e.g. <i>ENG1D1</i> <i>MPM1D1</i>	e.g. <i>ENG1P1</i> <i>CGC1P1</i>	e.g. <i>ENG1L1</i> <i>SNC1L1</i>	e.g. <i>AVI1O1</i> <i>PPL1O1</i>	e.g. <i>ENG1D1E</i> <i>MPM1D1E</i>
<i>Lead to university programs, etc.</i>	<i>Lead to college/ apprenticeship programs, etc.</i>	<i>Lead to the workplace</i>		<i>Inquiry-based learning for students who are identified gifted, pre-IB, and/or talented in area</i>

e-Learning

- ***Geography, English, Math, Science, French, BTT101***
- ***independent learners***
- ***be prepared to read a lot of material online***
- ***have initiative to work independently online many hours per week***
- ***students are not assigned to a classroom, but may work in the library, cafeteria or guidance office with some indirect supervision***
- ***should have a history of Excellent Learning Skills on successive elementary report cards***
- ***ask your teacher for a recommendation on the option sheet if you plan to enroll***

Dundas Valley Secondary School Grade 9 Option Sheet Compulsory Courses

To be completed by the Grade 8 Teacher/Principal		
Academic	Applied	Locally Developed
ENG1D1	ENG1P1	ENG1L1
ENG1D1E		
MPM1D1	MFM1P1	MAT1L1
MPM1D1E		
SNC1D1	SNC1P1	SNC1L1
FSF1D1	FSF1P1	FSF1O1*
CGC1D1	CGC1P1	
IEP Exceptionality: <input type="radio"/> NE (non-exceptional) <input type="radio"/> MID <input type="radio"/> Comm. L.D. <input type="radio"/> Gifted <input type="radio"/> Other _____ <input type="radio"/> Empower Reading recommended <input type="radio"/> Jump Math recommended <input type="radio"/> If student is interested in eLearning(++) (s)he has strong independent learning skills <input type="radio"/> Authorized Elementary French Exemption <input type="radio"/> Fewer than 600 hours French instruction (*to take FSF1O1)		
Grade 8 Teacher or Principal: Name: _____ Signature: _____		

To be completed by the Student and Parent/Guardian			
Compulsory Courses (6)	Academic	Applied	Locally Developed
English	ENG1D1	ENG1P1	ENG1L1
	ENG1D1E		
	ENG1D1eL++	ENG1P1eL++	
Mathematics	MPM1D1	MFM1P1	MAT1L1
	MPM1D1E		
	MPM1D1eL++	MFM1P1eL++	
Science	SNC1D1	SNC1P1	SNC1L1
	SNC1D1eL++	SNC1P1eL++	
French	FSF1D1	FSF1P1	FSF1O1*
	FSF1D1eL++	FSF1P1eL++	
Geography	CGC1D1	CGC1P1	
	CGC1D1eL++	CGC1P1eL++	
Phys. Ed.	PPL1O1F (Female)	PPL1O1M (Male)	

Option Sheet – Optional Courses

You will take two of the following options. Please rank your choices 1, 2, 3 , and we will do our best to accommodate your first two choices.	
	ADA2O1 – Drama
1	AMI1O1 – Music
	AVI1O1 – Visual Arts
	BBI1O1 – Intro. to Business
3	BTT1O1 – Info. Tech. (Bus. Computers)
	BTT1O1el++ – Info. Tech. (Bus. Computers)
	HIF1O1 – Intro. to Family Studies
	LVLBD1 – Latin
2	LWGBD1 – German
	LWSBD1 – Spanish
	PAL1O1 – Basketball
	TIJ1O1 – Exploring Technology (Tech.)



Math - Applied

8. Ruth works as a translator. She charges her customers a fixed consulting fee of \$20, plus 23¢ per word.

Which expression shows Ruth's charge, in dollars, for translating a document with n words?

a $(20 + 0.23)n$

b $(20 - 0.23)n$

c $20n - 23$

d $20 + 0.23n$



Math - Academic

Jared uses the equation $C=30n$ to determine the cost, C , in dollars, for renting a car for n days, where n is a whole number. If Jared can spend a maximum of \$200 on the rental, which of the following describes the possible values of n ?

- F 7, 8, 9, ...
- G 6, 7, 8, 9, ...
- H 0, 1, 2, 3, 4, 5, 6
- J 0, 1, 2, 3, 4, 5, 6, 7



Math - Applied

13. Examine the figure below.

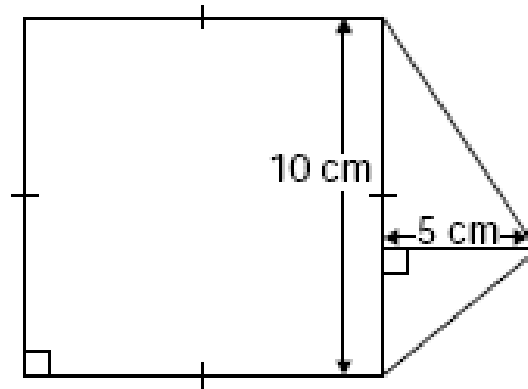

What is the total area of the figure?

a 150 cm^2

b 145 cm^2

c 140 cm^2

d 125 cm^2



Math - Academic

15. Examine the tent below.

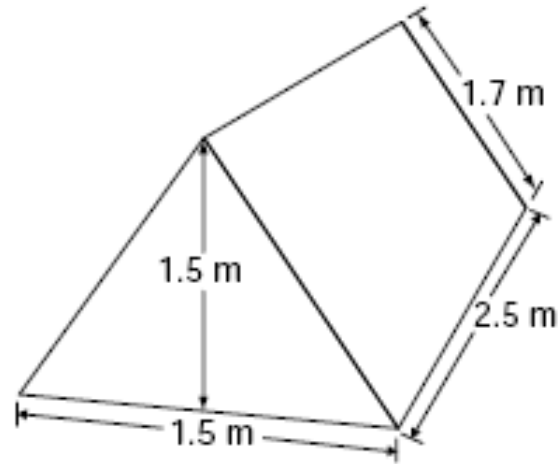

Which of the following is the surface area of the tent, including the ends and the floor?

a 4.6 m^2

b 10 m^2

c 14.5 m^2

d 20.0 m^2



English - Applied

 show that you can understand what you read

 use writing to communicate in various forms





 use research skills

 learn methods of how to organize information

 relate issues you read about to your personal lives



English - Academic

-  demonstrate strong comprehension skills and good writing skills
-  improve analytical and critical thinking skills
-  explore themes in literature from various historical periods and various locations ... e.g. poetry, novels, Shakespeare
-  independent reading/writing as homework

Get Involved

...in the arts



SPECIALIST HIGH SKILLS MAJOR

SHSM

Ontario.ca/SHSM

IMAGINE...
An opportunity to
test drive a career!

Get Involved

...in the athletics



Get Involved

...Special Events

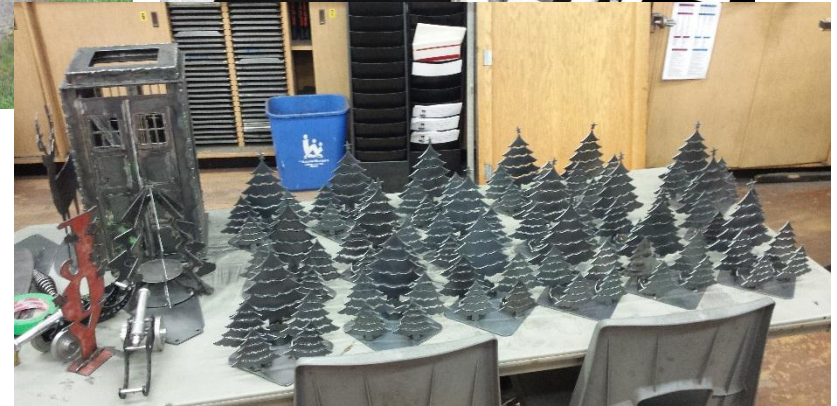

Get Involved

...in clubs, councils and contests

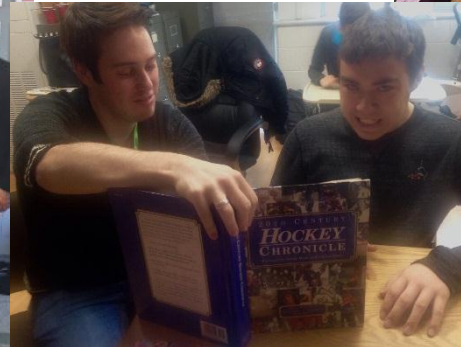

See www.hwdsb.on.ca/dundasvalley for a listing of all opportunities for students





Timelines

- **January** - option presentations to schools
- students carry home paper copies of registration form and option sheet
- **February** - paperwork due to elementary school
- **By March** - option entry in Career Cruising at elementary school



Career Cruising Option Entry

Sir William Osler – February 21

Seaton – February 27

Dundas Central – March 1

Spencer Valley - February 27

Course Planning

- Students can connect their high school course plans to careers and post-secondary programs of interest.
- Students are also able to track graduation and SHSM requirements

The screenshot displays the 'My Course Plan' interface. At the top, it shows 'My Progress' at 7% with a progress bar. The main area is a grid of course cards for Years 9 through 12. Each card includes the course name, code, and credit value. For example, Year 9 includes English (ENG1DI), Principles of Mathematics (MPM1DI), Science (SNC1DI), Geography of Canada (CGC1DI), Core French (FSF1DI), Healthy Active Living (PPL1OF), Comprehensive Arts (ALC1OI), and Religion - Be With Me (HRE1OI). Year 10 includes English (ENG2DI), Science (SNC2DI), Principles of Mathematics (MPM2DI), Canadian History in the 20th Century (CHC2DI), Career Studies (GLC2OH), Civics (CHV2OH), Healthy Active Living (PPL2OF), and Religious Education (HRE2OI). Year 11 includes English (ENG3UI), Functions (MCR3UI), Chemistry (SCH3UI), Marketing: Goods, Services, and Money (BMI3CI), Financial Accounting (BAF3MI), Business Dual Credit (YUA4TX), and Biology (SBI3UI). Year 12 includes English (ENG4UI), Business Leadership (BOG4EI), Communications Technology (TGJ4MI), Issues in Human Rights (IDC4UI), American History (CHA3U), and English (ENG1PI). The interface also features a 'Graduation Tracking' section showing 30/30 credits earned (20) and planned (10), and a 'Program Possibilities' section with a bar chart and counts for Apprenticeships (0), College Programs (0), University Programs (0), and My Programs (0). There are also sections for SHSM (Construction) and Interest Only (1 Course(s)). A 'SUBMIT' button is visible at the bottom of the course grid.

Questions?



More Information for Parents

 Pathway Planning Grades 9-12

 IPP

 Career Cruising

 The Guidance Office



IPP and Career Cruising

IPP = Individualized Pathway Plan

- every student will have an electronic IPP that will be updated at least twice annually...

Creating Pathways to Success, 2013

- HWDSB has purchased the rights to Career Cruising to facilitate the electronic IPP



Pathway Thinking:



- 5 Initial Destinations
- Most students will pursue more than one destination (i.e. college then university or workplace then college)
- Many new college/university transfer agreements and combined programs

Education and Career/Life Planning: A Four Step Process



Keep it broad...think in employment clusters or sectors

Architecture and Construction

Arts and Culture

Business and Finance

Computers and Telecommunications

Education and Social Services

Fashion and Design

Law and Government

Medical and Health

Natural Resources and Transportation

Science and Engineering

Service

Skilled Trades

Sports and Recreation

Personal IPP Account

With their personal IPP account students can:

- View a summary of the information they have saved
- Track their progress as they work towards school/district requirements
- Personalize their account by adding a photo
- Access their information from anywhere in the program

The screenshot shows the CareerCruising website interface for a user named Emilie LeBlanc. The header includes the site name, navigation links for 'Français', 'Help', and 'My Account', and a search bar. Below the header, the user's name and profile picture are displayed, along with a 'My Plan' dropdown menu and navigation links for 'Assessments', 'Careers', 'Education', and 'Employment'. A secondary navigation bar includes 'My Plan', 'Build My Resume', 'Share My Plan', and 'Print My Plan'. The main content area features a profile summary for Emilie LeBlanc, a 'My Progress' bar at 77%, and a 'View Details' link. A sidebar on the left lists various account sections like 'My Assessments', 'My Careers', 'My Education', etc. The main content area also displays 'My Assessments' with a 'Career Matchmaker' section and a 'Learning Styles Inventory' showing results for Visual Learning (30%), Auditory Learning (50%), and Tactile Learning (20%).



World Class Assessments

Using our various assessment tools, students can:

- discover how they best learn and retain information
- identify careers that suit their interests and;
- understand how their skills and abilities are related to those careers.

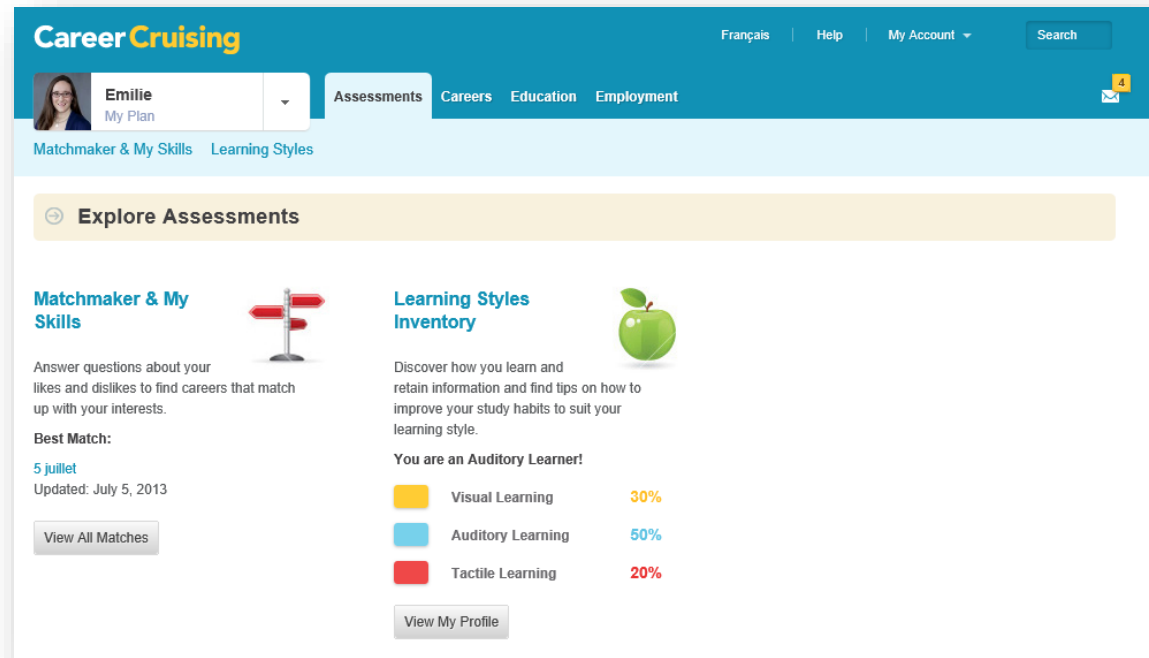

The screenshot displays the CareerCruising website interface. At the top, the logo 'CareerCruising' is visible on the left, and navigation links for 'Français', 'Help', and 'My Account' are on the right. A search bar is also present. Below the header, the user's name 'Emilie' and 'My Plan' are shown. The main navigation menu includes 'Assessments', 'Careers', 'Education', and 'Employment'. The current page is titled 'Matchmaker & My Skills' and 'Learning Styles'. A prominent yellow banner reads 'Explore Assessments'. Two main assessment cards are featured: 'Matchmaker & My Skills' and 'Learning Styles Inventory'. The 'Matchmaker & My Skills' card includes a red signpost icon, a description of the tool, and a 'View All Matches' button. The 'Learning Styles Inventory' card features a green apple icon, a description, and a bar chart showing learning style percentages: Visual Learning (30%), Auditory Learning (50%), and Tactile Learning (20%). A 'View My Profile' button is located at the bottom of the Learning Styles card.

Learning Style	Percentage
Visual Learning	30%
Auditory Learning	50%
Tactile Learning	20%



Detailed Career Information

Students can explore hundreds of careers using a variety of methods.

The screenshot shows the 'Explore Careers' section of the CareerCruising website. At the top, there is a navigation bar with the user's name 'Emilie My Plan' and tabs for 'Assessments', 'Careers', 'Education', and 'Employment'. Below the navigation bar, there is a search bar with the text 'Search for Careers' and a 'Career Selector' button. The main content area features a 'Keyword Search' field with a 'Search' button. Below the search bar, there are four tabs: 'Index', 'School Subjects', 'Alberta Senior High Clusters', and 'Alberta Junior High Clusters'. Under the 'Index' tab, there is a grid of letters from A to Z for alphabetical navigation. A 'Career Selector' sidebar is visible on the right, with a 'Start Career Selector' button.

Students will then have access to detailed multi-media career profiles.

The screenshot shows the 'Civil Engineer' profile page on CareerCruising. The page has a blue header with the user's name 'Emilie My Plan' and navigation tabs. The main content area is titled 'Civil Engineer' and includes a 'Save to My Plan' button. The profile is organized into sections: 'At a Glance', 'Suitable for You?', 'Job Description', 'Working Conditions', 'Earnings', 'Education', 'Sample Career Path', 'Related Careers', and 'Other Resources'. The 'At a Glance' section provides a brief overview of the profession. The 'Job Description' section includes a paragraph about the role of civil engineers. The 'Core Tasks' section lists several key responsibilities. A 'Photos & Interviews' section features a photo of a woman working at a desk, with a 'View PhotoFile' button. The 'Job Search' section at the bottom allows users to search for postings. The page also includes a 'Workplace' and 'Earnings' section.



Postsecondary Planning

Students have access to information about post-secondary institutions and apprenticeships available across the country.

The screenshot shows the Career Cruising website interface. At the top, there is a navigation bar with the logo, user profile (Emilie), and menu items: Assessments, Careers, Education, and Employment. Below the navigation bar, there is a search bar and a dropdown menu for 'My Plan'. The main content area is titled 'Explore Education & Training' and features a search bar for 'Colleges & Universities' and 'Programs'. A map of Canada is displayed, with provinces and territories labeled with their abbreviations: YT, NT, NU, BC, AB, SK, MB, ON, QC, PE, NB, and NS. To the right of the map, there are two informational boxes: 'Apprenticeships' and 'U.S. Schools', each with a 'Learn more' button.

The screenshot shows the Career Cruising website interface, specifically the 'Explore Apprenticeships' section. The navigation bar is identical to the previous screenshot. The main content area is titled 'Explore Apprenticeships' and features a search bar for 'Apprenticeships' and 'Provincial Profiles'. Below the search bar, there is a grid of icons representing various industry clusters: Agriculture & Horticulture, Manufacturing, Construction & Mining, Service Industry, Electronics, Power & Communications, Transportation & Mechanics, and Graphic Arts & Culture. To the right of the grid, there is an 'About Apprenticeships' box with a 'Learn more' button.

Employment Readiness

Students also have access to resources to help them prepare for the world of work, including an integrated job search and resume builder.

The screenshot shows the Career Cruising website interface. At the top, there is a blue navigation bar with the logo "Career Cruising" on the left, and links for "Español", "Help", and "My Account" on the right. A search bar is also present. Below the navigation bar, a user profile for "Jane" is visible, along with a menu of categories: "Assessments", "Careers", "Education", "Financial Aid", and "Employment". The "Employment" category is selected, and sub-links for "Employment Guide", "Job Search", and "Resume Builder" are shown. The main content area features three columns: "Employment Guide" with a pencil icon and a "Learn more" button; "Job Search" with a magnifying glass icon and a search form with fields for "Job / Position" and "Location", and a "Find Jobs" button; and "Build My Resume" with a document icon and a "Build My Resume" button. A "Jump to a section:" list is on the left, and "More Options" are listed at the bottom.

Career Cruising Español | Help | My Account ▾ Search

Jane My Plan ▾ Assessments Careers Education Financial Aid **Employment**

15

Employment Guide Job Search Resume Builder

→ **Employment**

Employment Guide

Learn how to conduct an effective work search and read our advice for your first days on the job.

↗ Learn more

Jump to a section:

- [Work Search](#)
- [Resumes](#)
- [Letter Writing](#)
- [Interview Skills](#)
- [Job Offers](#)
- [On the Job](#)

Job Search

Search for postings on thousands of job boards and company websites at once, using our Job Search tool.

Job / Position

Job title, keywords, or company name

Location

Enter city and state or zip code

🔍 Find Jobs

Build My Resume

Use the information from My Plan to create your resume.

↙ Build My Resume

More Options

- [Advanced Search](#)
- [Job Search Help](#)
- [Keywords for My Saved Careers](#)

Parent Engagement

Career Cruising's Parent Portal provides parents and guardians with access to their child's My Plan work.



The screenshot shows the Career Cruising Parent Portal interface. At the top, there is a dark blue header with the text "CAREER CRUISING" in white. Below this is a lighter blue navigation bar with a home icon, the text "Parent Portal", and buttons for "Français" and "Logout". The main content area has a dark blue header with "Parent Dashboard" in white. On the left, a light blue sidebar contains a welcome message "Welcome Chris Allinson!" and a list of navigation links: "Dashboard", "My Account", "Messages (0)", "Add a Child", and "Logout". Below these is a "More Information" section with links for "About Career Cruising", "What is the Parent Portal?", and "About the Parent Portal (PDF)". The main content area features a white background with a blue header for "Jane Smith". Below this, there are sections for "School" (Northern High School), "Grade Level" (Grade 11), and "Last Student Login" (8/23/2013 4:15:00 PM). To the right of these sections are icons for a folder and a pencil, with links "View Jane's Portfolio" and "Explore Career Cruising". A "Portfolio Completion Status" section shows a progress bar at 90% and links for "View Details" and "What is this?". At the bottom, the "CareerCruising" logo is displayed in blue and yellow, followed by the text "Terms of Use - Privacy - Contact Us - © Career Cruising".

CAREER CRUISING

Parent Portal [Français](#) [Logout](#)

Parent Dashboard

Welcome Chris Allinson!

- » [Dashboard](#)
- » [My Account](#)
- » [Messages \(0\)](#)
- » [Add a Child](#)
- » [Logout](#)

More Information

- » [About Career Cruising](#)
- » [What is the Parent Portal?](#)
- » [About the Parent Portal \(PDF\)](#)

The Parent Portal allows you to view and comment on the work your child has done in Career Cruising, keep track of his or her progress, receive messages from counselors and teachers at his or her school or school district, and explore Career Cruising.

Jane Smith

School
Northern High School  [View Jane's Portfolio](#)

Grade Level
Grade 11  [Explore Career Cruising](#)

Last Student Login
8/23/2013 4:15:00 PM

Portfolio Completion Status
90% [View Details](#) | [What is this?](#)

CareerCruising

[Terms of Use](#) - [Privacy](#) - [Contact Us](#) - © Career Cruising

Guidance Office Personnel

Counsellors' alphabetical caseload:

A-C Mr. Meyer

D-M Mrs. Lawson

N-Z Ms. Henderson

Student Success Teacher: Ms. Burleigh

Administrative Assistant: Mrs. Kelly

Social Worker: Mr. McCann

Public Health Nurse: Mrs. Kelly

AY Counsellor: Ms. Sawesky

Guidance Services Provided:

- Academic/career counselling and IPP
- Connect students and parents to community resources for mental health, addiction, financial assistance
- Post-secondary information and applications, scholarships
- Graduation, Awards Assembly
- Timetable changes
- Liaise with teachers, Learning Resource, and parents to assist students

Further Information

Websites:

HWDSB www.hwdsb.on.ca

D.V.S.S. www.hwdsb.on.ca/dundasvalley/

Ministry of Education www.edu.gov.on.ca/eng/



Questions?

Thank you for engaging in your child's education!